

TECNO-LIFT

PERMANENT-ELECTRO MAGNETIC SYSTEMS

ECO-COMPATIBILITY

No consumption
No pollution

Ideal for handling:

- Single plates
- Milled blocks
- Slabs
- Forged blocks
- Structural steel and section bar
- Plates on cutting machines

in the most advanced industrial environments:

- Distribution and storage
- Surface treatment
- Steel structural work
- Metalworking
- Shipbuilding
- Iron metallurgy
- Rolling mills



TECNOMAGNETE®

Safety through power

PERMANENT-ELECTRO TELESCOPIC BEAMS

- High-strength steel tube structure (Fe 510B)
- On board hydraulic system for the telescopic beam extension
- Magnetic modules with monobloc construction fitted with elastic suspension for automatic adaptation to load shape and bending
- APC magnetic power selector
- Cross beams selection

OPTIONALS

- AVC/1 Automatic spring cable reel
- SRM 90° Manual Rotation System of cross beams



TM 4

For single plate handling up to 12m.

Version with 4 cross beams with 2 magnetic modules each.



QUADSYSTEM TECHNOLOGY. SAFETY AND POWER TO SQUARE

Quadsystem permanent-electro circuit: the power of an electromagnet joined to the autonomy of the permanent magnet. Tecnomagnete designed and patented this unique and totally innovative technology, the QUADSYSTEM.

The clamping surface is composed by square poles in chess-board disposition, so that a **large power is concentrated** into the load.

The patented "neutral crown" guarantees a **perfect insulation** of the permanent magnets surrounding 5 sides of the magnetic poles, generating the power.

The technology of the double magnet permanent-electro **saves a 95%** of an equivalent electromagnetic lifter; the electrical power acts only some seconds in activation "MAG" and deactivation "DEMAG" cycles.

As the system is immune to power outages it **doesn't require back-up batteries** and is **fully safe** for operator and equipment with no space or time limitations.

TECNO-LIFT modules do not present any wearable and movable component, therefore they can grant an **high reliability and no maintenance** is generally required.

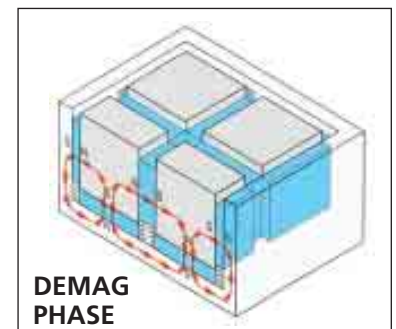
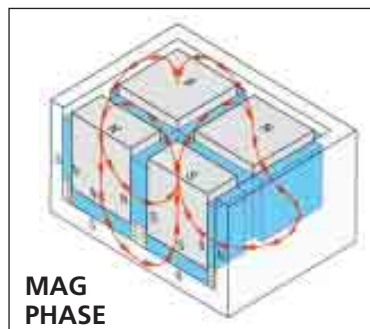



TM 6

For single plate handling up to 16 m.

Version with 6 cross beams with 2 magnetic modules each.



INNOVATIVE SOLUTIONS FOR TOTAL SAFETY

ELECTRONIC CONTROL EQUIPMENT

with Push-button Strip (ON-OFF, PICK-UP, FULL MAG, DEMAG, SAFE) installed on board in IP54 cubicle, for fast activation and deactivation operations (7 seconds maximum).

DOUBLE MAGNETIZATION CYCLES PICK-UP & FULL MAG

for checking load hold for every operation by partial module magnetization (PICK-UP) and travelling at the end of the 2nd full magnetization (FULL MAG).

RADIO CONTROL

gives long-distance control of PICK-UP, FULL MAG, SAFE, OPEN, CLOSE far from the material handling area.

POWER CONTROL

4-level APC Power Control System integrated with Control Unit.

SAFE PUSH BUTTON

to prevent accidental dropping. Load release requires operator to press 2 buttons simultaneously.

DAUTANAC

magnetic switch for magnetizing and demagnetizing only with loose chain.

UCS SATURATION CONTROL UNIT

checks whether current has reached the threshold necessary for full magnetic saturation of modules.

LAMP BLOCK

signals system status and/or alarm.

CHAIN PULL

made of grade 80 high strength steel.

THE VALUE OF EXPERIENCE

Tecnomagnetete has supplied permanent electro-magnetic systems for 25 years with continuing commitment to research and development of ever more advanced technological solutions ensuring SAFETY, POWER, CONVENIENCE, SAVINGS and – not the least – RESPECT FOR THE ENVIRONMENT. Quality, price and professionalism are Tecnomagnetete's competition arms made available to the steel industry through a skilled sales organization spread wide in the world with an efficient, fast service proven by thousands of systems built.

PRACTICAL USE AND COST-EFFECTIVENESS

Magnetism is the most rational mean of handling ferrous loads.

The new series of TECNO-LIFT permanent-electro lifters are fast and functional.

They pick up, move and set down the load easily controlled by a single operator staying at a safe distance.

They are convenient because they always work above the load with no need of maneuvering area or spacers between loads.

They never deform or compress the load and the working areas get optimized.

VERSATILITY AND RELIABILITY

The TECNO-LIFT family is made up of a broad range of models differentiated by pole geometry and magnetic volumes suited to the specific characteristics of the load including weight, thickness, dimensions and operation air gaps.

TECNO-LIFT modules are designed and built with special attention to COMPACTNESS, LOW WEIGHT, STRENGTH and RELIABILITY with full respect of CE and international standards.

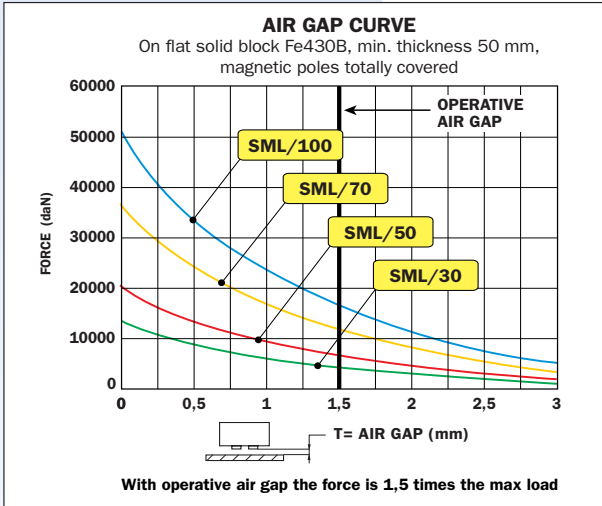
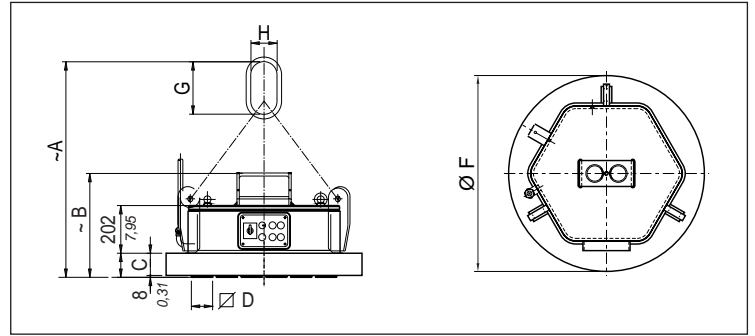

Model	NOMINAL DIMENSIONS								Weight		
SML	A	B	C	D	E	F	G	H			
30	mm in	1070 42.1	440 17.3	94 3.7	90 3.5	-	760 29.9	222 8.7	111 4.4	kg lb	500 1100
50	mm in	1070 42.1	440 17.3	94 3.7	90 3.5	-	760 29.9	222 8.7	111 4.4	kg lb	500 1100
70	mm in	1070 42.1	440 17.3	94 3.7	90 3.5	-	810 31.9	222 8.7	111 4.4	kg lb	550 1210
100	mm in	1140 44.9	440 17.3	94 3.7	90 3.5	-	950 37.4	266 10.5	133 5.2	kg lb	700 1540

Model	LOAD CHARACTERISTICS							
SML	Lenght		Width		Thick.	Max load		
	min.	max.	min.	max.	min.			
30	mm in	1000 39.4	5000 196.9	1000 39.4	2500 98.4	8 0.3	kg lb	3000 6600
50	mm in	1000 39.4	5000 196.9	1000 39.4	2500 98.4	8 0.3	kg lb	5000 11000
70	mm in	1000 39.4	5000 196.9	1000 39.4	2500 98.4	8 0.3	kg lb	7000 15400
100	mm in	1000 39.4	5000 196.9	1000 39.4	2500 98.4	8 0.3	kg lb	10000 22000

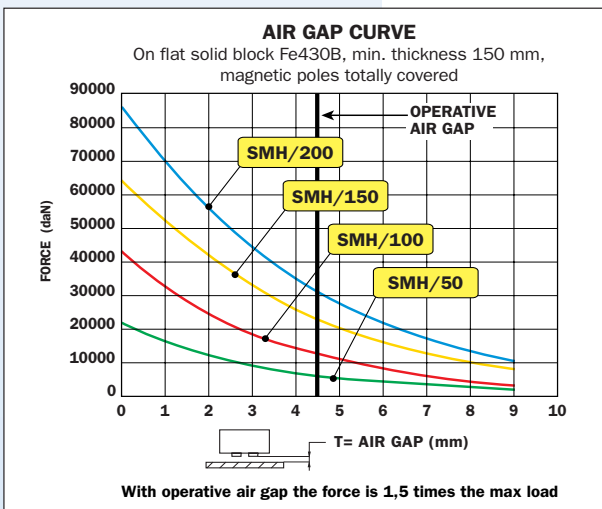
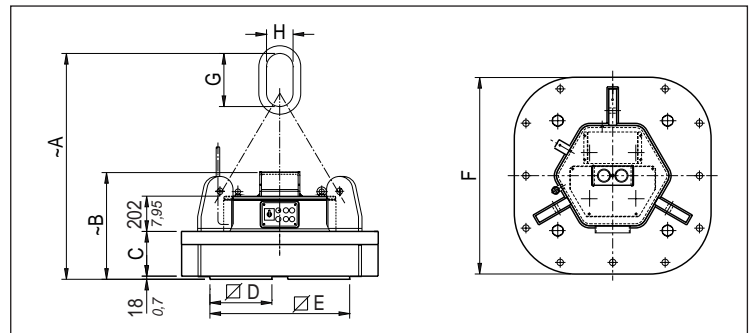

Model	NOMINAL DIMENSIONS								Weight		
SMH	A	B	C	D	E	F	G	H			
50	mm in	1170 46.1	530 20.9	175 6.9	205 8.10	480 18.9	800 31.5	222 8.7	111 4.4	kg lb	900 2000
100	mm in	1270 50.0	570 22.4	215 8.5	290 11.4	650 25.6	900 35.4	266 10.5	133 5.2	kg lb	1500 3300
150	mm in	1510 59.4	610 24.0	255 10.0	355 14.0	780 30.7	1070 42.1	266 10.5	133 5.2	kg lb	2300 5000
200	mm in	1530 60.4	630 24.8	280 11.0	410 16.1	890 35.0	1230 48.4	304 12.0	152 6.0	kg lb	3400 7500

Model	LOAD CHARACTERISTICS							
SMH	Lenght		Width		Thick.	Max load		
	min.	max.	min.	max.	min.			
50	mm in	1000 39.4	6000 236.2	1000 39.4	2500 98.4	30 1.2	kg lb	5000 11000
100	mm in	1000 39.4	6000 236.2	1000 39.4	2500 98.4	30 1.2	kg lb	10000 22000
150	mm in	1000 39.4	6000 236.2	1000 39.4	2500 98.4	40 1.6	kg lb	15000 33000
200	mm in	1000 39.4	6000 236.2	1000 39.4	2500 98.4	40 1.6	kg lb	20000 44000



SINGLE MODULES

SML

For handling single plates or semifinished blocks.

SML permanent electro-magnetic modules are the ideal answer for handling where operational air gaps are small.

- Favorable ratio between the hoisting load and the lifter weight.
- Multipole circuit to spread uniformly the force.
- APC magnetic power selector.
- Compact size and reduced weight.
- Innovative technology.

OPTIONAL

- AVC/1 Automatic spring cable reel



SMH

For handling single thick slabs and forged blocks.

SMH permanent electro-magnetic modules are designed for hoisting loads with big operational air gaps.

- 4-pole circuit for high force concentration.
- High magnet power.
- APC magnetic power selector.
- Compact size and reduced weight.

OPTIONAL

- AVC/1 Automatic spring cable reel



BEAM AND SECTION UNITS

TP

For handling merchant beams and sections.

Modular systems combining the benefits of safe hoisting, compactness and convenience. Their specially shaped profile allows overturning of beams on the ground and easy loading on racks or vehicles.



FIX BEAMS

BF 2

For handling single plates up to 6 m

Version with 2 cross beams with 2 magnetic modules each.

- High-strength steel-tube structure (Fe 510B)
- Magnetic modules with monobloc construction fitted with elastic suspension for automatic adaptation to load shape and bending
- APC Power Regulator

OPTIONALS

- AVC/1 Automatic spring cable reel
- SRM 90° Manual Rotation System of cross beams



TILTING BEAMS

TB

For handling single plates up to 12 metres long.

Fixed beams with tilting modules provide **vertical** plate handling. This joins the intrinsic safety of permanent electromagnet systems to compactness and great warehouse space saving:

- Compact structure made in electro-welded high resistance steel
- Tilting modules suspended on ball bearing



FIX BEAMS FOR CUTTING SYSTEMS

TT

For handling single plates and skeleton of cutting.

TT modular systems are tailor made by adapting them to the size of the plate and the cutted pieces. They allow easy and fast loading & unloading operations on any type of cutting machines (plasma, oxyacetylene, laser, high definition). In particular they free the bench from cut plate and skeleton in a single move to make the machine immediately available.



Max "wing" admitted related to steel sheet thickness

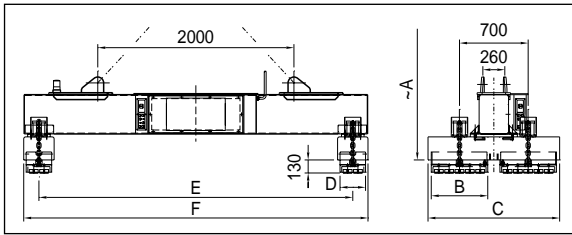
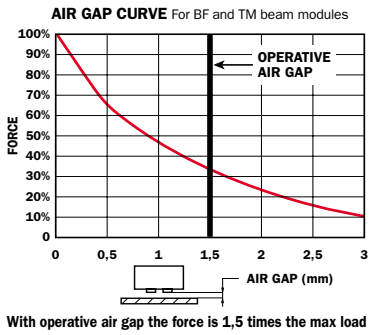
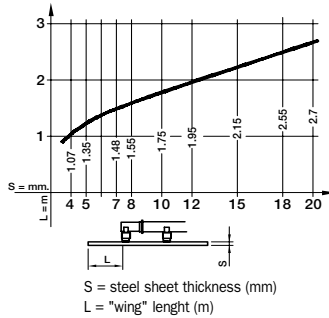

Model	NOMINAL DIMENSIONS						
BF	A	B	C	D	E	F	Weight
2/40	1900 74,80	490 19,29	1236 48,66	220 8,66	2800 110,24	3020 118,90	kg 1000 lb 2205
2/60	1900 74,80	490 19,29	1236 48,66	220 8,66	2800 110,24	3020 118,90	kg 1000 lb 2205
2/75	1900 74,80	490 19,29	1236 48,66	220 8,66	2800 110,24	3020 118,90	kg 1000 lb 2205
2/100	1900 74,80	576 22,68	1472 57,95	260 10,24	2800 110,24	3060 120,47	kg 1400 lb 3086

LOAD CHARACTERISTICS									
Lenght	min.	max.	Width	min.	max.	Thick.	min.	Max	
									load
3000	118,11	6000	236,22	500	19,69	3000	118,11	6	kg 4000 lb 8818
3000	118,11	6000	236,22	500	19,69	3000	118,11	8	kg 6000 lb 13228
3000	118,11	6000	236,22	500	19,69	3000	118,11	8	kg 7500 lb 16535
3000	118,11	6000	236,22	500	19,69	3000	118,11	10	kg 10000 lb 22046

BF 2

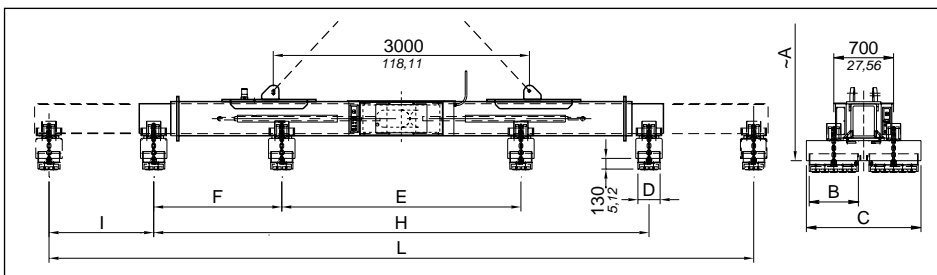

TM 4

Model	NOMINAL DIMENSIONS										
TM	A	B	C	D	E	F	G	H	I	L	Weight
4/60	2450 96,46	490 19,29	1236 48,66	220 8,66	2200 86,61	1300 51,18	-	4800 188,98	1200 47,24	7200 283,46	kg 2600 lb 5732
4/80	2450 96,46	490 19,29	1236 48,66	220 8,66	2800 110,24	1500 59,06	-	5800 228,35	1500 59,06	8800 346,46	kg 2800 lb 6172
4/100	2450 96,46	490 19,29	1236 48,66	220 8,66	2800 110,24	1500 59,06	-	5800 228,35	1500 59,06	8800 346,46	kg 2800 lb 6172
4/120	2450 96,46	490 19,29	1236 48,66	220 8,66	2800 110,24	1500 59,06	-	5800 228,35	1500 59,06	8800 346,46	kg 2800 lb 6172
4/150	2450 96,5	490 19,29	1236 48,66	220 8,66	2800 110,24	1500 59,06	-	5800 228,35	1500 59,06	8800 346,46	kg 2800 lb 6172
4/200	2450 96,46	576 22,68	1472 57,95	260 10,24	2800 110,24	1500 59,06	-	5800 228,35	1500 59,06	8800 346,46	kg 3200 lb 7055

LOAD CHARACTERISTICS									
Lenght	min.	max.	Width	min.	max.	Thick.	min.	Max	
									load
2500	98,43	10000	393,70	500	19,69	3000	118,11	4	kg 6000 lb 13228
3000	118,11	12000	472,44	500	19,69	3000	118,11	6	kg 8000 lb 17637
3000	118,11	12000	472,44	500	19,69	3000	118,11	8	kg 10000 lb 22046
3000	118,11	12000	472,44	500	19,69	3000	118,11	8	kg 12000 lb 26455
3000	118,11	12000	472,44	500	19,69	3000	118,11	8	kg 15000 lb 33069
3000	118,11	12000	472,44	600	23,62	3500	137,80	10	kg 20000 lb 44092

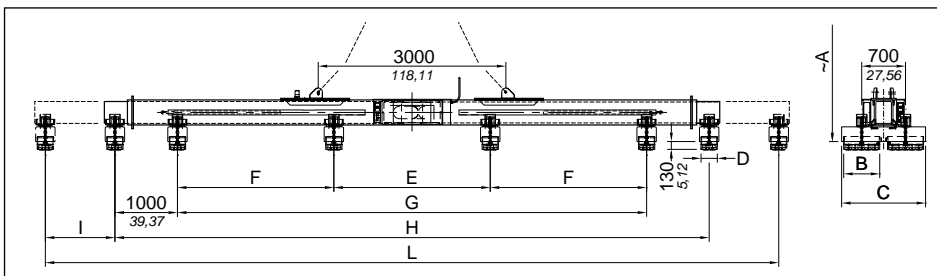

TM 6

Model	NOMINAL DIMENSIONS										
TM	A	B	C	D	E	F	G	H	I	L	Weight
6/80	2450 96,46	490 19,29	1236 48,66	220 8,66	2000 78,74	1800 70,87	5600 220,47	7600 299,21	1200 47,24	10000 393,70	kg 3700 lb 8157
6/100	2450 96,46	490 19,29	1236 48,66	220 8,66	2000 78,74	1800 70,87	5600 220,47	7600 299,21	1200 47,24	10000 393,70	kg 3700 lb 8157
6/120	2450 96,46	490 19,29	1236 48,66	220 8,66	2600 102,36	2600 102,36	7800 307,09	9800 385,83	1500 59,06	12800 503,94	kg 4000 lb 8818
6/150	2450 96,46	490 19,29	1236 48,66	220 8,66	2600 102,36	2600 102,36	7800 307,09	9800 385,83	1500 59,06	12800 503,94	kg 4000 lb 8818
6/200	2450 96,46	490 19,29	1236 48,66	220 8,66	2600 102,36	2600 102,36	7800 307,09	9800 385,83	1500 59,06	12800 503,94	kg 4000 lb 8818
6/250	2450 96,46	576 22,68	1472 57,95	260 10,24	2600 102,36	2600 102,36	7800 307,09	9800 385,83	1500 59,06	12800 503,94	kg 4800 lb 10580

LOAD CHARACTERISTICS									
Lenght	min.	max.	Width	min.	max.	Thick.	min.	Max	
									load
2500	98,43	12000	472,44	500	19,69	3000	118,11	4	kg 8000 lb 17637
2500	98,43	12000	472,44	500	19,69	3000	118,11	4	kg 10000 lb 22046
2800	110,24	16000	629,92	500	19,69	3000	118,11	8	kg 12000 lb 26455
2800	110,24	16000	629,92	500	19,69	3000	118,11	8	kg 15000 lb 33069
2800	110,24	16000	629,92	500	19,69	3000	118,11	8	kg 20000 lb 44092
2800	110,24	16000	629,92	600	23,62	3500	137,80	10	kg 25000 lb 55116

GTR 4/6: On request – units for 4 to 6 magnetic plates with control equipment for hooking to existing crosspieces.

**THE BROAD RANGE OF TECNO-LIFT PERMANENT-ELECTRO MAGNETIC SYSTEMS
ALLOWS HANDLING ANY TYPE OF FERROUS LOAD**



CV

Modules for handling cold-rolled coils, vertical eye.



BR

Modules for handling slabs, even on harbour cranes.



CO

Modules for handling open coils, vertical eye.



TU

Modules for handling layers of seamless pipe.



CH

Modules for handling cold-rolled coils, horizontal eye.



RO

Modules for handling layers of rails.



RD

Modules for handling rounds.



BL

Modules for handling layers of billets up to 450° C.



EM

Electromagnetic modules for handling bundles.



Bat Grip

Bat Grip Permanent electric battery lifters for loads up to 3000 kg.

All data were prepared and checked with the greatest care but we do not accept responsibility for any errors or omissions. We reserve the right to make changes connected with technical progress.



Headquarters

Safety through power
TECNOMAGNETE®

TECNOMAGNETE S.p.A.
Via Nerviano, 31 - 20020 Lainate (MI) - ITALY
Tel. +39+02.937.591 - Fax +39+02.935.708.57
<http://www.tecnomagnete.com>

Subsidiaries and offices abroad:

Brazil: TECNOMAGNETE R.O.
France: TECNOMAGNETE S.A.R.L.
Germany: TECNOMAGNETE GmbH
Japan: TECNOMAGNETE R.O.
Sweden: TECNOMAGNETE AB
P.R. China: TECNOMAGNETE R.O.
UK: TECNOMAGNETE Ltd
USA: TECNOMAGNETE Inc.